

Imperial 50 lb. (27 L.) Fryers



Model IFS-50

Fryer Features

- Stainless steel frypot, front, sides, door, stub back, and basket hanger.
- Large 5" (127) stainless steel landing ledge on Range Match model.
- 6" (152) stainless steel legs with non-marking feet. Plate mounted for secure support.
- One year parts and labor warranty. Limited warranty on stainless steel frypot is 5 years pro-rated.
- AGA and CGA design certified, NSF and CE listed.



Model Numbers

- IFS-50
- IFS-50SS - Range Match

Fryer Features

- 50 lbs. (27 L.) stainless steel frypots with radius formed edges.
- Four high efficiency cast iron tube-fired burners provide a large heat transfer area for a fast recovery. Rated at 140,000 BTU/hr. (41 KW).
- Tubes are precision welded on the outside of the frypot for added durability. Welds are robotically welded for consistency.
- Unique baffle and deflectors inside the tubes diffuse heat to the tube wall to ensure even heat.
- Large "cool zone" captures food particles and keeps them from carbonizing in the fry zone.
- Millivolt temperature control circuit.
- Snap acting thermostat has a 200°F - 400°F (93°C - 204°C) temperature range.
- Manual or optional programmable computer controls available.
- 100% safety shut-off valve.
- Two large nickel-plated wire mesh fry baskets with ergonomic, polyurethane coated handles.
- Fine mesh crumb screen.
- 1 1/4" (32) full port ball valve for quick draining.

All measurements in () are metric equivalents.

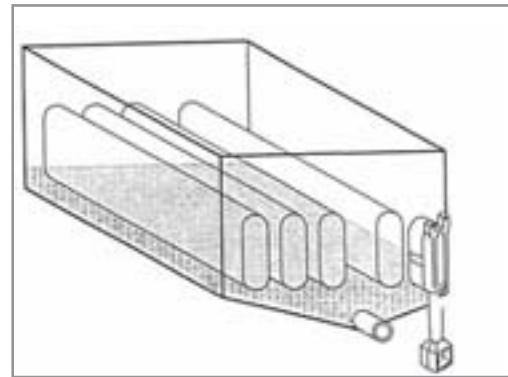

Tube fired heating system - Four immersed tubes 140,000 BTU/hr. (41 KW).

Imperial Commercial Cooking Equipment

1128 Sherborn Street ■ Corona, CA 92879 ■ 800.343.7790 ■ Ph: 951.281.1830 ■ Fx: 951.281.1879
www.imperialrange.com ■ E-mail: imperialsales@imperialrange.com

Imperial 50 lb. (27 L.) Fryers

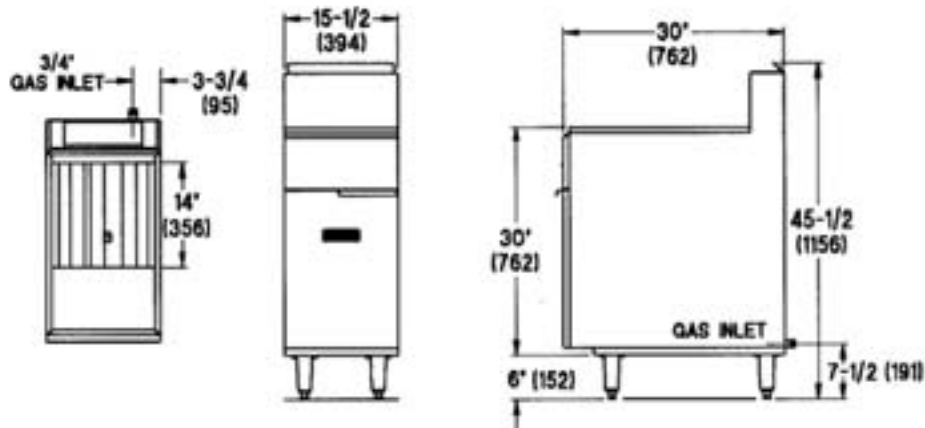

50 lb. (27 L.) Fryers

Model#	Description	Oil Capacity		Gas Output		Ship Wt.	
		Lbs.	(Liters)	BTU	(KW)	(Kg.)	Lbs.
IFS-50	Stainless Steel Frypot	50	(27)	140,000	(41)	(114)	253
IFS-50SS	Range Match with Stainless Steel Frypot	50	(27)	140,000	(41)	(114)	253

All measurements in () are metric equivalents.

Crated Dimensions: 36" (891) d x 18" (461) w. Add 2" (51) to height of unit.

Standard Exterior Finish Specifications

Front, sides, door, stub back and basket hanger shall be constructed of stainless steel with welded and finished stainless steel seams. Stainless steel legs shall be plate mounted and include non-marking feet.

Frypot Specifications

All precision welded stainless steel vessel shall be constructed of heavy 16 gauge stainless steel. Vessel shall have a large foam area to prevent overflow. All vessel edges shall be radius formed for added durability. Frying area shall be 14" x 14" (356 x 356) with a 50 lbs. (27 L.) oil capacity. There shall be three 14 gauge stainless steel, fully immersed heat transfer tubes for maximum efficiency. Heat retaining baffles and deflectors shall be inside of tubes and easily removed for cleaning. Tube joints shall be welded on the outside of specially drawn fry vessels to prevent leaks. Gas output shall be 140,000 BTU/hr. (41 KW). Snap acting thermostat shall have a 200°F - 400°F (93°C - 204°C) temperature range. Fail-safe high limit control shall shut off all gas if oil temperature exceeds 435°F. (224°C). Safety pilot shall be 100% shut off. Large cool zone beneath tubes shall capture food and breading particles and keep them out of the frying area to improve food taste and prolong oil life. Fine mesh crumb screen shall be removable. Unit shall include removable drain pipe and clean out rod. Drain shall be a 1 1/4" (32) full port drain valve for quick draining.

Gas

Manifold pressure is 4" W.C. for natural gas or 11" for propane gas. Manifold size 3/4" NPT. 3/4" pressure regulator supplied with equipment to be installed at time of connection. Specify type of gas and elevation if over 2,000 ft. (610 m).

Clearance

For use only on non-combustible floors. Legs or casters are required for non-combustible floors; or 2" (51) overhang is required when curb mounted. Provide 0" clearance from non-combustible surfaces and 6" (152) from combustible surfaces.

Optional Items

- Rear gas pressure regulator
- Portable oil filter unit
- Fryer drain station with a storage cabinet
- Quick disconnect hose and restraining device
- Stainless steel strip to cover between fryers
- Various size fry baskets
- 6" (152) swivel casters (front two casters are locking)
- Stainless steel backguard

Optional Fryer/Filter Systems

- Pre-packaged systems with matching cabinet and built-in filter and pan
- Stainless steel dump station and food warmer
- System options include solid state thermostat control, computer fry control and basket lifts



800-729-5051

Imperial Commercial Cooking Equipment

1128 Sherborn Street ■ Corona, CA 92879 ■ 800.343.7790 ■ Ph: 951.281.1830 ■ Fx: 951.281.1879
www.imperialrange.com ■ E-mail: imperialsales@imperialrange.com