



FLAV-R-FRESH® IMPULSE DISPLAY CABINETS

Models FDWD-1, FDWD-1X, FDWD-2, FDWD-2X

Hatco has a profitable way to create impulse food sales with the Flav-R-Fresh Holding and Display Cabinet. Controlled moisturized heat lets you display and hold hot foods longer using minimum counter space.

FLEXIBILITY

The Hatco Flav-R-Fresh has separate heat and humidity controls to keep crisp foods crisp and moist foods moist, not just for minutes but for hours. It holds everything from hot pretzels to 15" (381 mm) pizzas, croissants to bagels, and even hot dogs and meat pies.

Electrical components, controls, and water reservoir are located at the top for easy access. A digital temperature monitor indicates the cabinet temperature. A red light indicates a low water level and a green light shows the humidity cycle.

Models with two doors are available for pass-through convenience and a variety of merchandising racks help enhance food appeal.

The Hatco Flav-R-Fresh is ideal for restaurants, pizzerias, convenience stores, concession stands, snack bars, and kiosks.

QUALITY

The following features assure the finest performance for years to come:

- The new rounded Euro designed cabinet features tempered glass sides and door for full-view display.
- Shatter-resistant incandescent light enhances food appeal while safe-guarding food products from bulb breakage.
- Single- or double-door opening models provide fast access to food racks.
- Food decals and merchandising signs are available to help promote product.
- Available in six *Designer* colors: Warm Red, Black, Gray Granite, White Granite, Navy Blue, Hunter Green.

ZESCO.COM

800-729-5051



Model FDWD-2X with stationary 4-shelf multi-purpose rack and optional three sided sign holder (signs not included)



Model FDWD-1 with rotating 4-tier rack, optional three sided sign holder (signs not included), and accessory decals and pans

Custom Food Decals & Merchandising Signs



Designed to attract attention and stimulate sales, Flav-R-Fresh offers a eye-catching food decals (Pizza, and Hot Pizza or Hot Pretzels in bright red with yellow letters)

METAL SHEATHED AIR HEATING ELEMENTS GUARANTEED AGAINST BURNOUT AND BREAKAGE FOR TWO YEARS.



HATCO CORPORATION P.O. Box 340500 Milwaukee, WI 53234-0500 U.S.A.
 (800) 558-0607 • (414) 671-6350 • Fax (800) 543-7521 • Int'l. Fax (414) 671-3976
 www.hatcocorp.com • E-mail: equipsales@hatcocorp.com

Form No. FDWD Spec Sheet

Printed in U.S.A.
 September 2007



FLAV-R-FRESH® IMPULSE DISPLAY CABINETS

Models FDWD-1, FDWD-1X, FDWD-2, FDWD-2X

800-729-5051

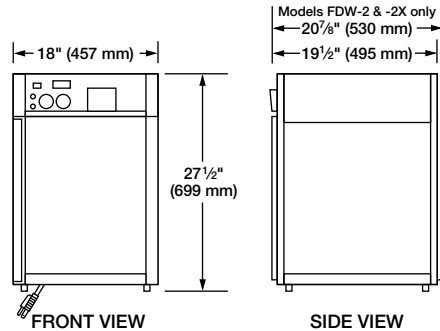
**DIMENSIONS**

FDWD-1, FDWD-1X: 19 $\frac{3}{8}$ " W x 20 $\frac{7}{8}$ " D x 28 $\frac{5}{8}$ " H
(492 x 530 x 727 mm).

FDWD-2, FDWD-2X: 19 $\frac{3}{8}$ " W x 22" D x 28 $\frac{5}{8}$ " H
(492 x 559 x 727 mm).

Cabinet Opening: 15 $\frac{3}{4}$ " W x 19 $\frac{3}{4}$ " H
(400 x 502 mm).

VOLTAGE

120 volts, 60 Hz, 1420 watts, 11.8 amps (uses NEMA 5-15P).

Export voltages available.

CORD LOCATION

Facing controls, right-hand side panel, lower right corner.

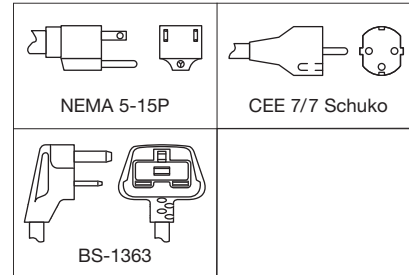
PLUG CONFIGURATIONS**SPECIFICATIONS**

Model*	Type	Rack Style	Shipping Weight
FDWD-1	1 Door	Circle Rack† with Rack Motor	80 lbs. (36 kg)
FDWD-1X	1 Door	Multi-Purpose Rack without Rack Motor	82 lbs. (37 kg)
FDWD-2	2 Doors	Circle Rack† with Rack Motor	86 lbs. (39 kg)
FDWD-2X	2 Doors	Multi-Purpose Rack without Rack Motor	88 lbs. (40 kg)

* Models FDWD-1 and FDWD-2 include rack motor. Models with "X" designator do not have revolving display and are NOT available for retrofit.

† Pretzel Rack available in lieu of Circle Rack.

WATER QUALITY REQUIREMENTS

Water supply in excess of 3.0 grains of hardness per gallon (GPG) (.75 grains of hardness per liter) must be treated and softened before being used. Water containing over 3.0 GPG (.75 GPL) will decrease the efficiency and reduce the operating life of the unit.

Note: Product failure caused by liming or sediment buildup is not covered under warranty.

OPTIONS (NOT FOR RETROFIT)

- Designer Colors: Warm Red, Black, Gray Granite, White Granite, Navy Blue, Hunter Green
- Three Sided Sign Holder

ACCESSORIES

- 4-Tier Circle Rack (Requires motorless rack coupling on -X models)
- 4-Shelf Multi-Purpose Rack (Each shelf 13 $\frac{5}{8}$ " W x 12 $\frac{5}{8}$ " D (346 x 321 mm))
- 4-Shelf Angle Rack (Each shelf 14" W x 14 $\frac{1}{2}$ " D (356 x 368 mm))
- 3-Tier Pretzel Tree (Requires motorless rack coupling on -X models)
- Motorless Rack Coupling (For -X models only)
- 4" (102 mm) Adjustable Legs with Brackets
- Merchandising Display Sign Holder
- Graphic Adhesive Decals (3 per set)
 - Pizza Photo
 - Hot Pizza
 - Hot Pretzel

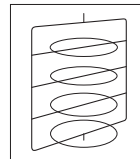
Display Rack Selection

4-Tier Circle Rack
Model FDWD4TCR
Rack Opening:
3 $\frac{1}{4}$ " (83 mm)
Maximum
15" (381 mm)
diameter pans

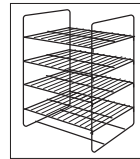

4-Shelf Multi-Purpose Rack*
Model FDWD4SMP
Rack Opening:
3 $\frac{1}{2}$ " (89 mm)

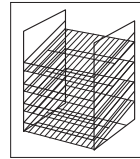

4-Shelf Angle Rack
Model FDWD4SAR
Rack Opening:
3 $\frac{3}{4}$ " (95 mm)

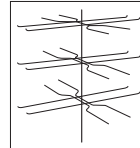

3-Tier Pretzel Tree
Model FDWD3TPT
Rack Opening:
5 $\frac{7}{8}$ " (149 mm)

* Accommodates half-size sheet pans (Not included).

PRODUCT SPECS**Impulse Display Cabinet**

The humidity controlled Impulse Display Cabinet shall be a Flav-R-Fresh® Model ...rated at ...volts and ...watts, as manufactured by the Hatco Corporation, Milwaukee, WI 53234 U.S.A.

With 24/7 parts and service assistance (U.S. and Canada only), the cabinet shall havedoor(s), tempered glass sides,

stationary rack (or revolving display), and incandescent display light. It shall include a water reservoir, humidity selector switch, temperature selector dial, on-off switch, and indicating lights. A 6' (1829 mm) cord with plug shall be attached.

Accessories shall include merchandising racks, display sign(s), and food graphic decals.

HATCO CORPORATION P.O. Box 340500 Milwaukee, WI 53234-0500 U.S.A. • (800) 558-0607 • (414) 671-6350
Fax (800) 543-7521 • Int'l. Fax (414) 671-3976 • www.hatcocorp.com • E-Mail: equipsales@hatcocorp.com